

Technical sheet :

M 40-2 ST5



	Technical characteristics		Metric
1.1	Manufacturer		MANITOU
1.2	Model Name		M 40-2 ST5
1.3	Power source		Diesel
1.4	Operator type		Seated
1.5	Max. capacity	Q	4000 kg
1.6	Load centre of gravity	c	500 mm
1.8	Load distance, centre of drive axle to fork	x	763 mm
1.9	Wheelbase	y	2060 mm
	Weight		
2.1	Service weight		6915 kg
2.2	Weight on front axle (laden) / rear axle (laden)		9075 kg / 1840 kg
2.3	Weight on front axle (Unladen) / rear axle (Unladen)		2625 kg / 4290 kg
	Wheels		
3.1	Tyres type		Pneumatic
3.2	Dimensions of front wheels		18-19,5 18PR A224
3.3	Dimensions of rear wheels		10R17,5 G291 GY
3.5	Number of front wheels / rear wheels		2 / 2
3.5.2	Number of drive wheels		2
3.6	Front wheel gauge	b10	1600 mm
3.7	Rear wheel gauge	b11	1640 mm
	Dimensions		
4.1	Tilt of Mast Forward (deg) / Backward (deg)	α / β	15 / 15
4.7	Height of overhead guard (cabin) / Overall height of low overhead guard (Buggie version)	h6 / h6*	2440 mm / 2440 mm
4.8	Seat height/stand height	h7	1407 mm
4.19	Overall length	l1	4858 mm
4.20	Length to face of forks	l2	3658 mm
4.21	Overall width	b1	2057 mm
4.22	Forks section x width x length	s / e / l	150 mm x 150 mm / 1200 mm
4.23	Fork carriage ISO 2328 (class/form) A/B		FEM 3A
4.24	Fork carriage width	b3	1670 mm
4.31	Ground clearance below mast	m1	250 mm
4.32	Ground clearance at centre of wheelbase	m2	377 mm
4.33	Aisle width for 1000 x 1200 pallet widthways	Ast	5560 mm
4.34	Aisle width for 800 x 1200 pallet lengthways	Ast	5560 mm
4.35	Turning radius	Wa	3395 mm
	Performances		
5.1	Travel speed (laden / unladen)		22 km/h / 22 km/h
5.2	Lifting speed (laden / unladen)		0.4 m/s / 0.4 m/s
5.3	Lowering speed (laden / unladen)		0.5 m/s / 0.4 m/s
5.5	Drawbar pull (Laden)		6900 daN
5.10	Service brake		Hydraulic
	Engine		
7.1	Engine brand / model / norm		Deutz / TCD 2,9 / Stage V
7.2	Engine power according to ISO 1585		55 kW
7.3	Rated speed		2300 rpm
7.4	Number of cylinders / Capacity of cylinders		4 - 2925 cm ³
7.5	Fuel consumption according to VDI cycle		5.5 l/h
	Miscellaneous		
8.1	Type of drive control		Electric
8.2	Working hydraulic pressure for attachments		210 Bar
8.3	Oil flow rate for attachments		97 l/min
8.4	Sound level at the driver's ear according to DIN 12 053		78 dB(A)

Dimensional drawing

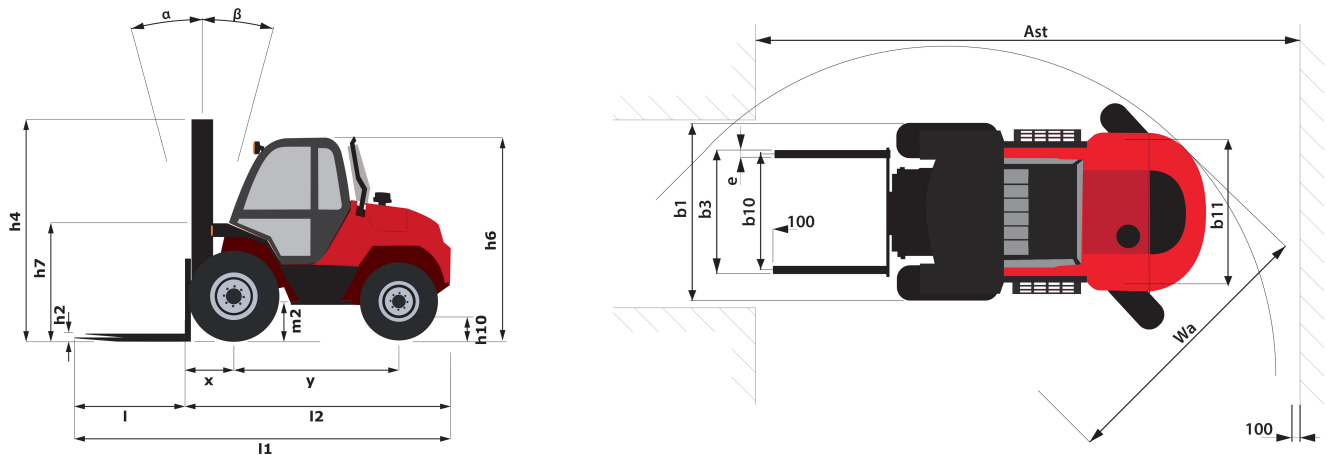

Characteristics of masts and residual capacities

Full Visibility Duplex		FVD 30	FVD 33	FVD 35	FVD 37	FVD 40	FVD 45	FVD 50
h1 - Height mast lowered *	mm	2475	2625	2725	2825	2975	3225	3475
h4 - Height mast extended *	mm	4025	4325	4525	4725	5025	5525	6025
h3 - Max. lifting height	mm	3000	3300	3500	3700	4000	4500	5000
α / β - Mast inclination (front / rear)	°	15 / 15	15 / 15	15 / 15	15 / 15	15 / 15	15 / 15	15 / 15
Residual capacity at max height	kg	4000	4000	4000	4000	4000	4000	
Residual capacity with hooked-on side shift (Off road load chart)	kg	4000	4000	4000	4000	4000		3600
Height at max capacity	mm	3000	3300	3500	3700	4000	4500	
Residual capacity without attachment (Off road load chart)	kg	4000	4000	4000	4000	4000	4000	
Height at max capacity with hooked-on sideshift	mm	3000	3300	3500	3700	4000		4000

Free Lift Triplex		FLT 37	FLT 40	FLT 43	FLT 45	FLT 47	FLT 50	FLT 55	FLT 60
h1 - Height mast lowered *	mm	2225	2325	2425	2500	2560	2675	2825	3000
h2 - Free lift	mm	1255	1355	1455	1530	1590	1705	1855	2030
h4 - Height mast extended *	mm	4725	5027	5325	5525	5725	6025	6525	7025
h3 - Max. lifting height	mm	3700	4000	4300	4500	4700	5000	5500	6000
α / β - Mast inclination (front / rear)	°	15 / 15	15 / 15	15 / 15	15 / 15	15 / 15	10 / 15	10 / 15	10 / 15
Residual capacity at max height	kg	4000	4000	4000	4000	3000		2500	
Residual capacity with hooked-on side shift (Industrial load chart)	kg	4000	4000						
Residual capacity with hooked-on side shift (Off road load chart)	kg				3650	3650			
Height at max capacity	mm	3700	4000	4300	4500	4200		4500	
Residual capacity without attachment (Off road load chart)	kg	4000	4000	4000	4000	3000		2500	
Height at max capacity with hooked-on sideshift	mm	3700			3500	4200			



Siège Social
430 rue de l'Aubinière - 44150 Ancenis Cedex - France
Tel: +33(0)2 40 09 10 11 - Fax: +33 (0)2 40 09 10 97
www.manitou.com



This brochure describes versions and configuration options for Manitou products which may be fitted with different equipment. The equipment described in this brochure may be standard, optional or not available depending on version. Manitou reserves the right to change the specifications shown and described at any time and without prior warning. The manufacturer is not liable for the specifications given. For more information, contact your Manitou dealer. Non-contractual document. Product descriptions may differ from actual products. List of specifications is not comprehensive. The logos and visual identity of the company are the property of Manitou and may not be used without authorisation. All rights reserved. The photos and diagrams contained in this brochure are provided for information only.

MANITOU BF SA - Limited company with board of directors - Share capital: 39,668,399 euros - 857 802 508
RCS Nantes